

Symmetrical Ray Diagrams of the Optical Pathways in Light Microscopes

Chris Hammond, Institute for Materials Research, University of Leeds, UK and Julian Heath, Cambridge, UK

BIOGRAPHY

Christopher Hammond (pictured) obtained his MA at Cambridge University, and his PhD in metallurgy from Leeds University. His research interests lie in the relationships between the structure and properties of metallic alloys in general, and titanium alloys in particular. His main areas of expertise are in polarised light microscopy, the interpretation of electron and X-ray diffraction patterns and crystallography. He is the author of *The Basics of Crystallography and Diffraction* (Oxford University Press, 2001) and the Honorary Keeper of the collection of 20th C microscopes in Oxford, UK.

Dr Julian Heath is the Editor of *Microscopy and Analysis*.



ABSTRACT

We present a new set of symmetrical ray diagrams of the optical pathways in transmitted, reflected and epifluorescence light microscopes equipped with infinity-corrected optics. It is intended that the symmetry and simplicity of these diagrams will aid both novice and experienced microscope users in their understanding of the principles of Köhler illumination and of image formation in the light microscope and will explain the reasons why the correct set-up and alignment of the microscope is so very important for the production of optimal images.

ACKNOWLEDGEMENTS

We are deeply indebted to Dr Peter Evennett for his valuable input into this project, and we would like to take this opportunity to acknowledge his major contribution to light microscopy over the years.

KEYWORDS

light microscopy, transmitted, reflected, fluorescence light microscopes, optical pathways, infinity-corrected optics, ray diagrams

AUTHOR DETAILS

Dr C. Hammond,
Institute for Materials Research,
University of Leeds,
Leeds LS2 9JT, UK
Tel: +44 (0)113 343 2382
Email: c.hammond@leeds.ac.uk
Email(JPH): ma.tech@btinternet.com

Microscopy and Analysis 20(5):5-8 (UK), 2006

INTRODUCTION

The light microscope consists of an illumination system before the specimen (object) and an imaging system after it. The optical components of the microscope comprise a sophisticated train of aberration-minimised multi-element lenses, prisms and beamsplitters that are integrated with a light source and a set of diaphragms. Together, these elements provide the high-quality images that modern microscopists demand. However, neither the outward appearance of a microscope (Figure 1a) nor the to-scale optical schematics supplied by the manufacturer (Figure 1b) are particularly helpful in providing useful information to the user as to how the light microscope actually works.

In geometrical optics, the pathways of light through optical systems are demonstrated by ray diagrams. Indeed, ray tracing is used in the design of the train of optical elements between the light source and the detector. Ray diagrams are also essential in the teaching of optics and microscopy. They can provide a clear demonstration of the mechanism of image formation and, importantly for users of light microscopes, they allow an understanding of the positions of the two sets of conjugate (aperture and field) planes and the functions of the diaphragms associated with them which is essential if a student or user is to obtain images of optimum resolution, quality and contrast.

But ray diagrams are not popular with students. (The late Professor Barer used to say that one such diagram was enough! [1]) It is certainly true that ray diagrams can appear very confusing to both novices and even experienced users and attempts to simplify them into separate diagrams showing the 'image-

forming rays' and the 'illuminating rays', or the 'orthoscopic' and 'conoscopic' ray diagrams in books on polarised-light microscopy [2], can only make things worse. A student may be forgiven for thinking that light paths suddenly and mysteriously change simply by removing the eyepiece or flipping in a Bertrand lens.

Furthermore, when the light microscope is represented by a ray diagram, it is difficult using ray paths to show an image magnification of say 100 \times because, obviously, the image would have to be drawn 100 \times larger than the object and the imaging part of the ray diagram would need to be hugely expanded.

An elegant solution to all these problems is to draw the light paths corresponding to a very low (3-4 \times) magnification and also show the illuminating and imaging systems as symmetrically related either side of the object plane. Such a ray diagram was produced in 1998 for the case of a light microscope with finite (i.e. 160 mm) tube length-corrected objectives [3]. Today, most new microscopes are designed with infinity-corrected optical systems, so a new set of ray diagrams is now called for.

In this article we now present a set of symmetrical ray diagrams of the optical paths in transmitted, reflected and epifluorescence light microscopes equipped with infinity-corrected objectives. The diagrams show the important similarities and differences in the optical trains of the three standard types of microscope.

SYMMETRICAL RAY DIAGRAM FOR TRANSMITTED LIGHT MICROSCOPE

Figure 2 shows a symmetrical ray diagram of a transmitted-light microscope with infinity-

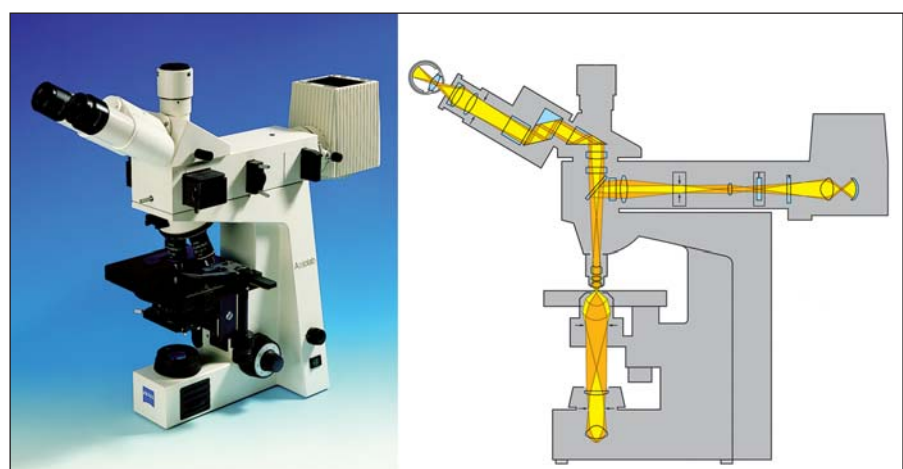

Figure 1: (a) A standard upright light microscope with transmitted- and reflected-light illumination systems. (b) Schematic of the optical pathways. Images courtesy of Carl Zeiss UK.

corrected optics. The first thing to observe in Figure 2 is the mirror symmetry of the illuminating and imaging optical components (represented by simple lenses) each side of the object plane: the condenser lens corresponds to the objective lens; the auxiliary lens corresponds to the tube lens; and the lamp collector lens corresponds to the eyepiece lens. The symmetry extends from the lamp filament (wavy red line) to its image which constitutes the exit pupil (aka Ramsden disc or eyepoint). It is at this point, where all the pencils of parallel rays converge, that the lens of the eye or camera is (or should be) placed. If not, then the most convergent pencils of rays will be cut off and the image will be vignetted.

We will now follow the ray paths from just three points on the filament: one in the centre of the filament, on the optical axis (the red rays) and two either side (the green and blue rays). First consider the rays emitted from the green point on the filament. Of course, the rays spread out in all directions, but we have just drawn three – two that just pass the outer limits of the field diaphragm and one that is parallel to the optical axis. As we follow these three rays through the microscope we see that the action of the lamp collector and auxiliary lenses is to recombine or focus these rays to form an image of the green point on the filament in front of the condenser. Hence, for all rays, an image (point by point) of the filament occurs and it is in the plane of this image of the filament that the illuminating aperture diaphragm is placed under the conditions of Köhler illumination.

The filament and its image are said to occur in conjugate planes (i.e. what is in focus in one plane is in focus in the other). Again, tracing the paths of these rays through the condenser lens and objective lens, we see that they are focused in the back focal plane of the objective lens, and, after passing the tube lens and eyepiece lens these rays are focused at a plane called the exit pupil. In short, the exit pupil is an image of the filament. (In practice it is usually demagnified and is best observed using a 10× or 20× magnifier.) The filament itself and the three planes in which it is in focus are called the aperture set of conjugate planes, marked A1-4 in Figure 2.

Now let us look at the pattern of light rays at the illuminated field diaphragm. Notice that the light from the GRB points on the filament (the green, red and blue rays) is focused at different points in this plane – the laterally inclined rays are focused at its margins

Figure 2: Symmetrical ray diagram of a transmitted light microscope with infinity-corrected optics, showing the object in a reflection plane of symmetry with respect to the optical components of the illuminating and imaging systems and the field set of conjugate planes (F1, F2, F3, F4), and at a centre of symmetry with respect to the aperture set (A1, A2, A3, A4) of conjugate planes.

Three sets of rays (green, red and blue) arising from three separate points (G, R, B) in the filament illuminate the whole area of the object as a series of parallel pencils of light and are focused in the aperture set of conjugate planes. The pupil of the eye is situated at or near the exit pupil and the lens of the eye produces the final image on the retina (or at the plane of the film or CCD detector in a camera, as shown in Figure 4).

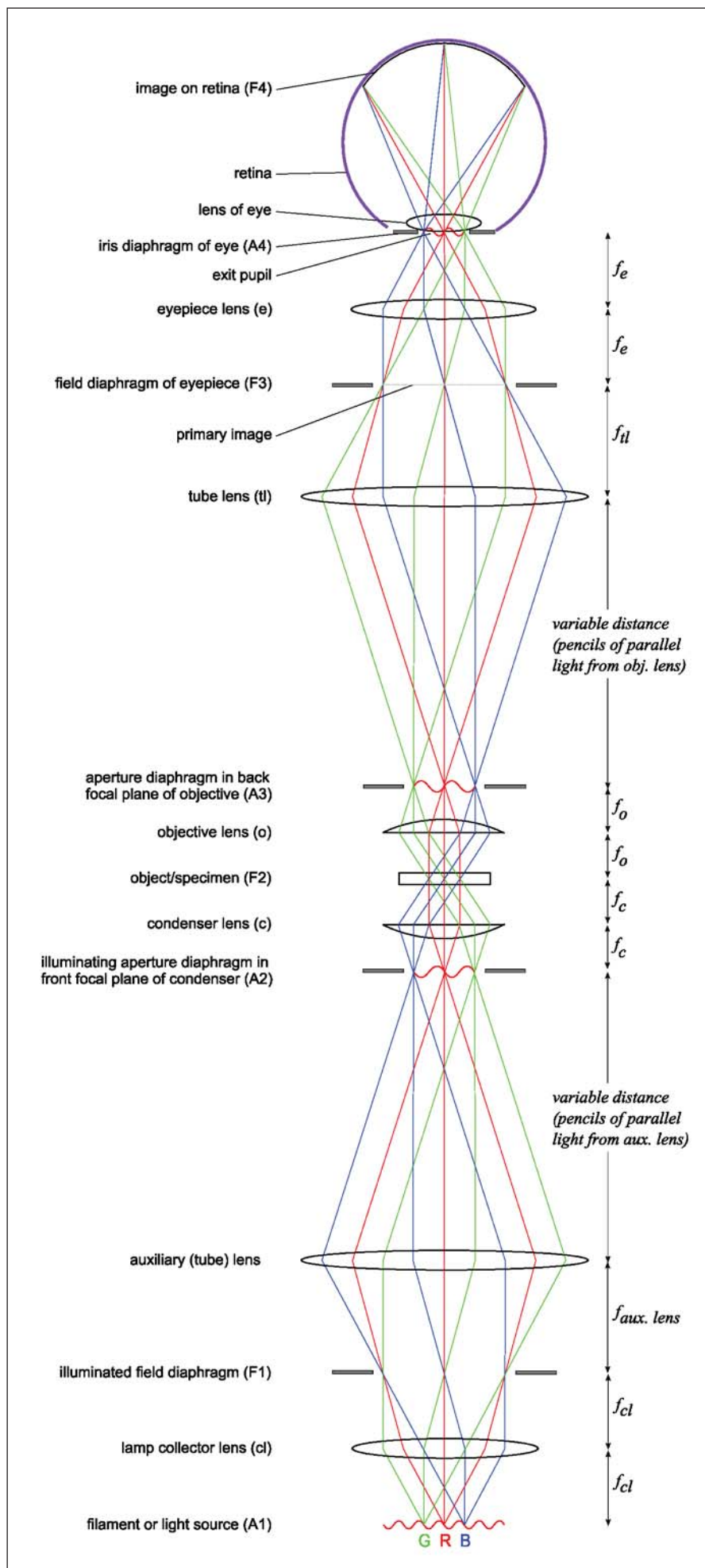

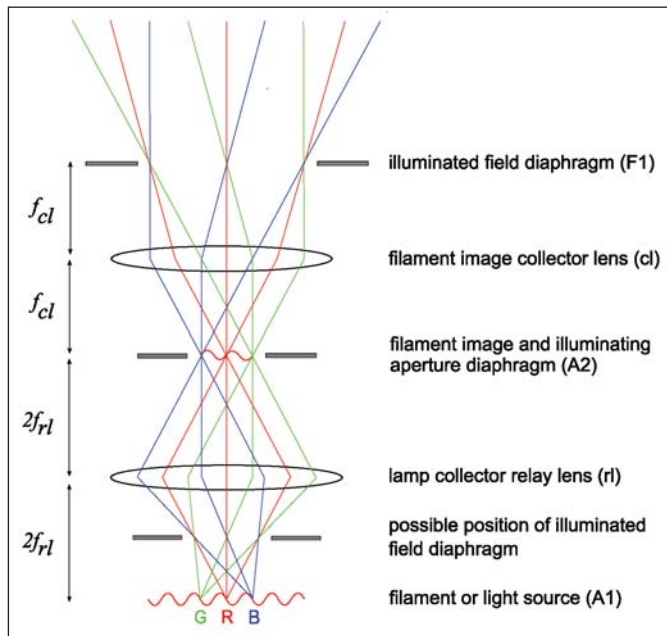

Figure 3: Extension to the ray diagram in Figure 2 showing an additional lamp collector relay lens which provides an image of the filament in the plane of the illuminating aperture diaphragm. This arrangement is an option for the illumination systems of transmitted-light microscopes but is required for reflected-light microscopes.

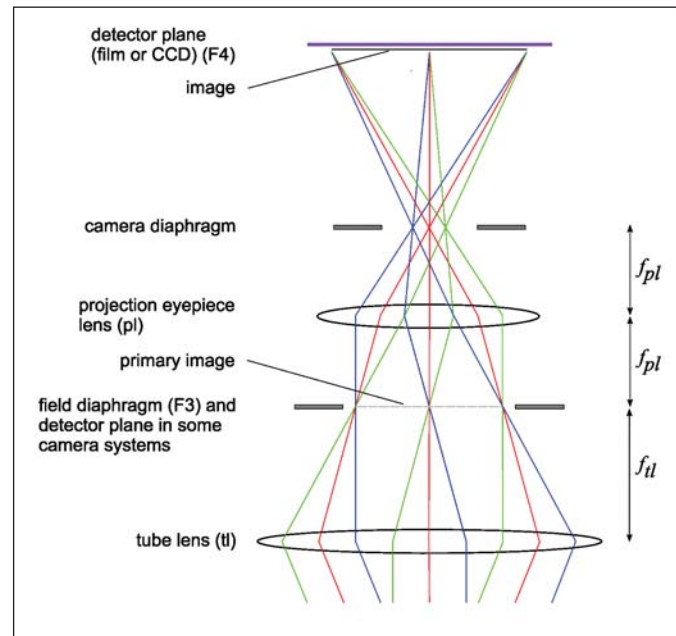

Figure 4: Modification of the imaging pathways shown in Figures 2 and 5 for the case when using a film or CCD camera. The detector is placed to coincide either with the plane of the eye retina or the primary image plane, e.g. in a dedicated side-mounted imaging extension on the microscope.

whereas the rays parallel to the optical axis are focused in the centre. This means that the illuminated field diaphragm is uniformly illuminated with light. It doesn't matter whether or not the green, red or blue rays are of equal intensity (i.e. that the light emanating from each region of the filament is of uniform intensity); if one set of rays is absent it just means that the uniform illumination will be weaker. This is the basis of Köhler illumination and we can see (following the rays through as before) that the same principle applies at the object itself, at the primary image and at the retina of the eye (or the film or CCD detector). These four planes – at the illuminated field diaphragm, object, primary image and retina/detector – are called the field set of conjugate planes, marked F1-4 on Figure 2.

Now, having begun to understand the light paths, we can proceed to understand the functions of the illuminated field and illuminating aperture diaphragms – for convenience we will just call them the field and aperture diaphragms.

If we decrease the size of the field diaphragm then the rays will illuminate a smaller area of the object, i.e. this diaphragm adjusts the illuminated field. If we decrease the size of the aperture diaphragm then a smaller area of the filament contributes to the illumination at the object and the angles of incidence of the rays at the condenser will be smaller. However, the illuminated field remains the same. It is very important to convince yourself of this fact because the setting of the aperture diaphragm is of vital importance in obtaining the optimum conditions for resolution and contrast. The sine of the half-angle of the cone of light illuminating the object (multiplied by the refractive index of the immersion oil in the case of an oil-immersion objective lens) is called the numerical

aperture (NA) of the condenser. In Figure 2 the condenser and objective lenses are precisely matched – they have identical focal lengths and numerical apertures and the object is placed exactly one focal length from each lens. Notice the symmetry once again: light diverging from points in the front focal plane of the condenser are projected as parallel pencils through the objective then focused again in the back focal plane of the objective lens.

Correspondingly, the light diverging from points in the object are projected by the objective lens as parallel pencils to infinity! The function of the tube lens is to focus these parallel pencils at the primary (or intermediate) image plane. The magnification M of the primary image is thus determined by the ratio f_{tl}/f_o and not by the magnification of the objective lens alone. So when you see infinity-corrected objective lenses marked 10 \times , this value assumes a certain focal length tube lens to go with them.

A particular benefit of using an infinity-corrected objective and a tube lens is that the light passing between them consists of parallel pencils so any optical accessory, such as retardation plates, fluorescence filters, beamsplitters, etc., can be placed in this region without upsetting the optical aberration-correcting properties of the objective lens.

In practice, the focal lengths and numerical apertures of the condenser and objective lenses are never precisely matched as in Figure 2. In order to match the focal lengths we would need a different condenser lens for each objective. This is achieved automatically in the reflected-light microscope, as described below, but for transmitted light we use the same condenser (perhaps with a flip-top lens: in for high powers and out for low powers) for a whole range of objectives.

The optical design of condensers is therefore

something of a compromise. One 'ideal' arrangement, which was used in the days of 'brass and glass', was to use as a condenser an identical objective lens 'in reverse'. However, this also suffered the defect that, except for very low powers, the front focal plane of the objective/condenser lens was inaccessible.

A further reason why, in practice, the NAs of the condenser and objective lenses are rarely matched as shown in Figure 2 is because this does not provide the optimum conditions for resolution and contrast. As the NA of the condenser is decreased (by decreasing the size of the condenser aperture diaphragm) resolution decreases but contrast increases. The optimum setting (dependent on the specimen) is when the NA of the condenser is between 2/3 and 4/5 of that of the objective. Decreasing it still further not only results in loss of resolution but, worse, the introduction of false detail.

The explanation of all these effects belongs of course to the domain of physical rather than geometrical optics.

SYMMETRICAL RAY DIAGRAM FOR REFLECTED LIGHT AND EPI-FLUORESCENCE MICROSCOPES

Figure 5 is a symmetrical ray diagram of a reflected-light or epifluorescence microscope equipped with infinity-corrected optics.

For reflected light, the ray diagram in Figure 2 may be considered to be folded twice over: first folded over in the plane of the object (so that the illuminating and imaging optical components coincide), and second in a plane at 45° to the optical axis in the parallel-light region between the objective lens and the tube lens.

The geometrical result is shown in Figure 5. The plane of the 45° folding corresponds to the position of a semitransparent beamsplitter reflector which admits light from the illumi-

Figure 5: Symmetrical ray diagram of reflected-light and epifluorescence microscopes with infinity-corrected optics, showing the object in a reflection plane of symmetry with respect to the optical components of the illuminating and imaging systems and the field set of conjugate planes (F1, F2, F3, F4), and at a centre of symmetry with respect to the aperture set (A1, A2, A3, A4) of conjugate planes. Three sets of rays (green, red and blue) arising from three separate points (G, R, B) in the filament illuminate the whole area of the object as a series of parallel pencils of light and are focused in the aperture set of conjugate planes. The pupil of the eye is situated at or near the exit pupil and the lens of the eye produces the final image on the retina (or at the plane of a film or CCD detector in a camera, as shown in Figure 4).

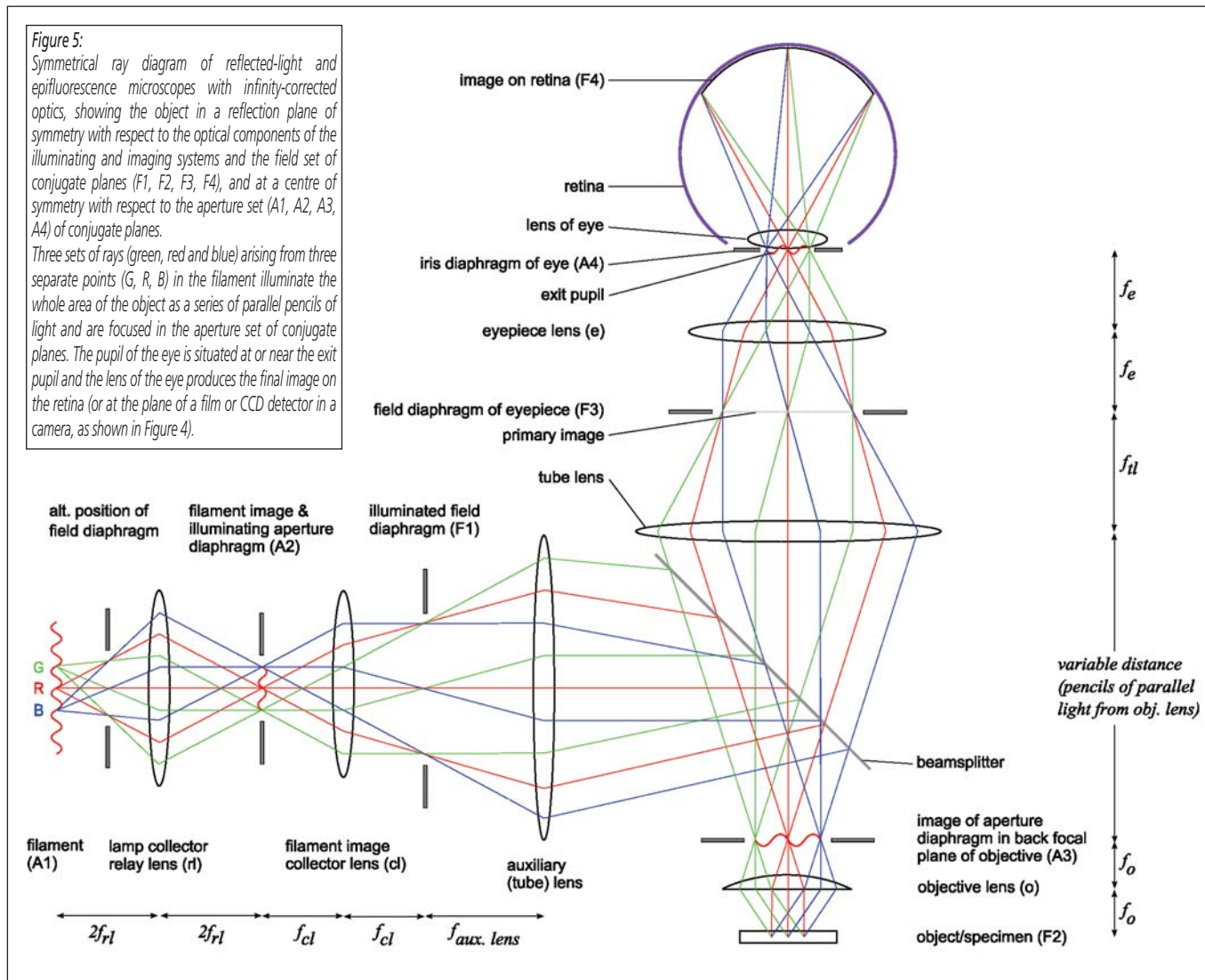

nating system at 90° to the major optical axis. Now we see that the condenser lens and objective lens are precisely matched: the same lens functions as both a condenser and objective lens. But there is one thing missing: the aperture diaphragm in the front focal plane of the condenser lens (now coincident with the back focal plane of the objective lens). An illuminating aperture diaphragm cannot be placed here because it would restrict the imaging aperture to that of the condenser. Instead, the illuminating system must project an image of the illuminating aperture diaphragm and filament into the back focal plane of the objective lens. In this way, as with transmitted light, the aperture of the objective lens can be adjusted independently of the aperture of the illumination system. The only conjugate plane upstream is at the filament itself. However, since this is inside a lamp it is usually inaccessible (and the aperture diaphragm would get rather hot, unless the source was an array of cool LEDs). The illuminating system therefore incorporates a further lens upstream, generally called a relay lens, which projects an image of the filament into this position. Such a relay lens is shown in the illuminating system in Figure 5 and in the optional extension to the transmitted light ray diagram (Figure 3).

The equal distances (twice the focal length) between the relay lens, filament and image correspond to the special case of a magnification of the filament of unity.

Figure 5 explains a commonly-heard query: "Why are the positions of the field and aperture diaphragms reversed in reflected light?" The answer is: "Because the aperture diaphragm has leapfrogged one conjugate plane upstream." Figure 5, and more clearly in Figure 3, show that the field diaphragm could in fact leapfrog to a position just in front of the filament (i.e. the focal length of the relay lens). Which position is chosen is a matter of individual microscope design (indeed, sometimes both are used) but the geometrical principles of all the designs are simple and the same.

Figure 4 shows that the final image may be recorded on film or CCD detector either at a plane corresponding to the retina (cf. Figures 2 and 5) or at the primary image plane. The latter configuration is often used in side-mounted dedicated camera extensions. (C-mount camera adapters usually incorporate a lens system which reduces the size of the primary image by a factor of 0.25 - 0.75.)

CONCLUSION

We have produced a set of symmetrical ray diagrams of the optical pathways in transmit-

ted, reflected and fluorescence light microscopes equipped with infinity-corrected optics. We hope that the symmetry and simplicity of these diagrams will aid both novice and experienced microscope users in their understanding of the principles of Köhler illumination and of image formation in the light microscope and will explain the reasons why the correct set-up and alignment of the microscope is so very important for the production of optimal images [see 4-6 for further info].

REFERENCES

1. Barer, R. *Teaching Microscopy to Medical Students. In: Teaching Microscopy (1st Edn).* pp78-92, Microscope Publications, Chicago, IL, 1977.
2. Hallimond, A. F. *The Polarizing Microscope.* 3rd Edn. Vickers Instruments, York, UK, 1996.
3. Hammond, C. A symmetrical representation of the geometrical optics of the light microscope. *Journal of Microscopy* 192(1):63-68, 1998.
4. Murphy, D. B. *Fundamentals of Light Microscopy and Electronic Imaging.* John Wiley and Sons Inc, NY, 2001.
5. Heath, J. P. *Dictionary of Microscopy.* John Wiley and Sons Ltd, Chichester, UK, 2005.
6. *Molecular Expressions Microscopy Primer website:* <http://micro.magnet.fsu.edu/primer/index.html>

©2006 John Wiley & Sons, Ltd